

Solenoid metering pump CONCEPT^{PLUS} 180 strokes/min

ProMinent®



The necessary retrofitting can be carried out at the customer's premises with a specially designed external control retrofit kit. This reduces storage costs without limiting flexibility.

The product range CONCEPT^{PLUS} covers the performance range from 0.74 l/h-10 bar to 14.9 l/h-1.5 bar. With its compact structure it is equally suitable for both conventional installation on a bracket or chemical tank and installation in machines such as slide grinding systems, car wash systems and dish-washers.

The metered quantity can be steplessly adjusted by means of the stroke length over a range of 10 % - 100 % and in four levels by means of the stroke rate. This results in an adjustment range of 1:40. As well as manual stroke rate adjustment the pump can be controlled by potential-free contacts from a water meter or controller. The pump can also be activated and deactivated with a potential-free contact.

A 'level' retrofit kit is available for connecting a level switch. The dosing heads are available in the material combinations PPE 2, PVT 2 and NPB 2 with bleed valve to cover virtually all metering tasks in water treatment.

CONCEPT^{PLUS} offers uncompromising quality and reliability at an extremely affordable price.

Solenoid metering pump CONCEPT^{PLUS} 180 strokes/min

Type	Type Pump capacity at max. back pressure			Pump capacity at medium back pressure			Stroke rate Strokes/min.	Connection size outØ x inØ mm	Suction lift* mWs	Shipping weight approx. kg
	bar	l/h	ml/stroke	bar	l/h	ml/stroke				
CNPb 1000	10	0.74	0.07	5	0.97	0.09	180	6x4	6	1.8
CNPb 1601	16	1.1	0.10	8	1.4	0.13	180	6x4	6	1.8
CNPb 1002	10	2.1	0.19	5	2.6	0.24	180	6x4	5	1.8
CNPb 0704	7	3.9	0.36	3,5	4.4	0.41	180	6x4	4	1.8
CNPb 0309	3	9.0	0.83	1,5	13.0	1.20	180	8x5	2	1.8
CNPb 0215	1.5	16.4	1.45	1	18.3	1.70	180	8x5	1.5	1.8

* Suction lift with a filled dosing head and suction line
Electrical connection: 100 V -230 V, 50/60 Hz
The system includes: 2 m mains cable with standard European plug, foot valve, injection valve, 2 m suction line and 5 m discharge line

Optional: External control retrofit kit 2 m control cable and level retrofit kit for connecting a one-stage level switch

Order no. 1046731



Wetted materials in different versions

Liquid end	Dosing head	Suction/pressure connector	Valve ball	Seals
PPE	Polypropylene	Polypropylene	Ceramic	EPDM
NPB	Acrylic	PVC	Ceramic	FPM B
PVT	PVDF	PVDF	Ceramic	PTFE

* DEVELOPAN® diaphragms with PTFE support in all versions

Addresses and delivery information from the Distributor

Siampathy Co., Ltd.
381/33 Taosura Rd.,
Muang Nakhonratchasima
Nakhonratchasima THAILAND
Tel : 044-255-271
Fax : 044-255-272
email : sales@siampathy.com
website : www.siampathy.com

Solenoid metering pump CONCEPT^{PLUS} 240 strokes/min

ProMinent®



The necessary retrofitting can be carried out at the customer's premises with a specially designed external control retrofit kit. This reduces storage costs without limiting flexibility.

The product range CONCEPT^{PLUS} covers the performance range from 0.74 l/h-10 bar to 14.9 l/h-1.5 bar. With its compact structure it is equally suitable for both conventional installation on a bracket or chemical tank and installation in machines such as slide grinding systems, car wash systems and dish-washers.

The metered quantity can be steplessly adjusted by means of the stroke length over a range of 10 % - 100 % and in four levels by means of the stroke rate. This results in an adjustment range of 1:40. As well as manual stroke rate adjustment the pump can be controlled by potential-free contacts from a water meter or controller. The pump can also be activated and deactivated with a potential-free contact.

A 'level' retrofit kit is available for connecting a level switch. The dosing heads are available in the material combinations PPE 2, PVT 2 and NPB 2 with bleed valve to cover virtually all metering tasks in water treatment.

CONCEPT^{PLUS} offers uncompromising quality and reliability at an extremely affordable price.

Solenoid metering pump CONCEPT^{PLUS} 240 strokes/min

Type	Type Pump capacity at max. back pressure			Pump capacity at medium back pressure			Stroke rate Strokes/min.	Connection size outØ x inØ mm	Suction lift* mWs	Shipping weight approx. kg
	bar	l/h	ml/stroke	bar	l/h	ml/stroke				
CNPb 1001	10	1.0	0.07	5	0.97	0.09	240	6x4	6	1.8
CNPb 1602	16	1.5	0.14	8	1.9	0.13	240	6x4	6	1.8
CNPb 1003	10	3.0	0.21	5	4.3	0.24	240	6x4	5	1.8
CNPb 0705	7	5.2	0.34	3,5	5.87	0.59	240	6x4	4	1.8
CNPb 0312	3	12.0	0.83	1,5	17.3	1.00	240	8x5	2	1.8
CNPb 0223	1.5	21.9	1.52	1	25.2	1.63	240	8x5	1.5	1.8

* Suction lift with a filled dosing head and suction line
Electrical connection: 100 V -230 V, 50/60 Hz
The system includes: 2 m mains cable with standard European plug, foot valve, injection valve, 2 m suction line and 5 m discharge line

Optional: External control retrofit kit 2 m control cable and level retrofit kit for connecting a one-stage level switch

Order no. 1046731



Wetted materials in different versions

Liquid end	Dosing head	Suction/pressure connector	Valve ball	Seals
PPE	Polypropylene	Polypropylene	Ceramic	EPDM
NPB	Acrylic	PVC	Ceramic	FPM B
PVT	PVDF	PVDF	Ceramic	PTFE

* DEVELOPAN® diaphragms with PTFE support in all versions

Addresses and delivery information from the Distributor

Siampathy Co.,Ltd.
381/33 Taosura Rd.,
Muang Nakhonratchasima
Nakhonratchasima THAILAND
Tel : 044-255-271
Fax : 044-255-272
email : sales@siampathy.com
website : www.siampathy.com

Solenoid Metering Pump
CONCEPT^{plus} CNPb

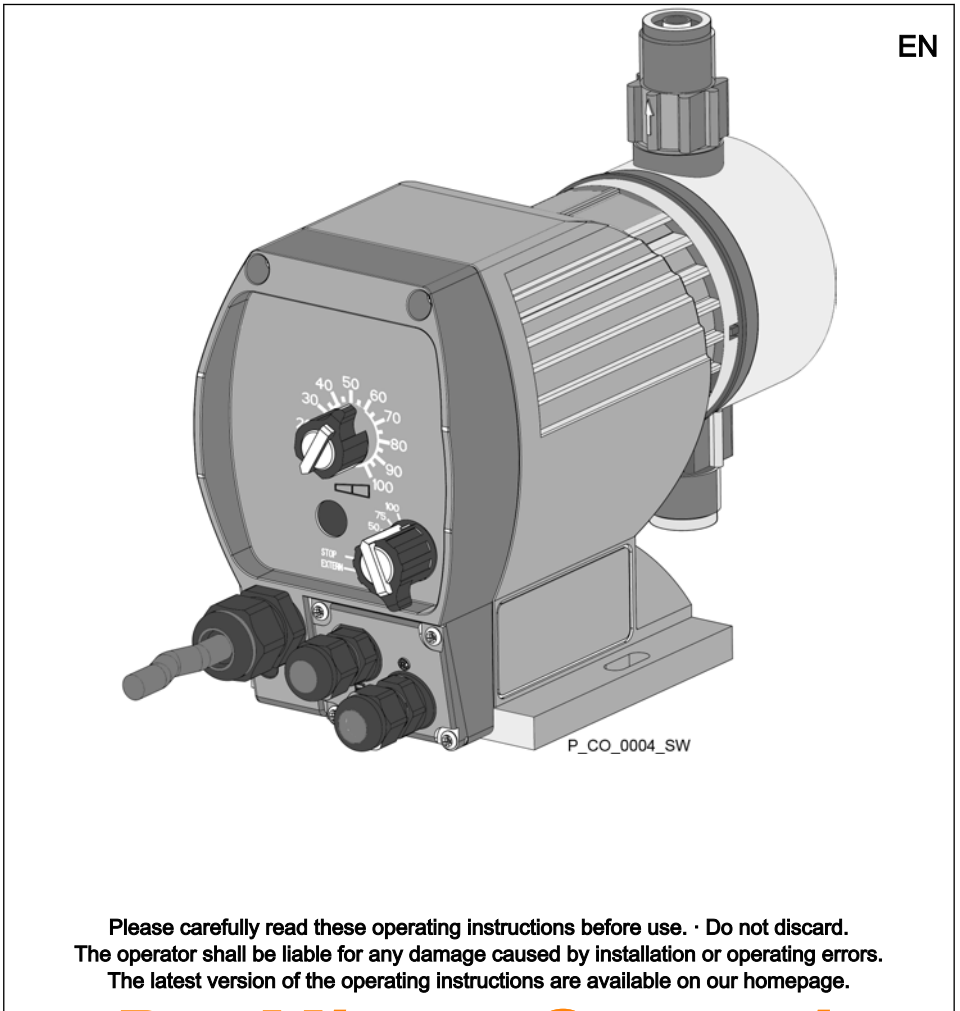

Supplementary information



Fig. 1: Please read!

Read the following supplementary information in its entirety! Should you already know this information, you will benefit more from referring to the operating instructions.

The following are highlighted separately in the document:

- Enumerated lists
- ➔ Operating guidelines
- ⇒ Outcome of the instructions

General user instructions

These operating instructions are only intended for skilled users responsible for the operating of oscillating metering pumps.

Information



This provides important information relating to the correct operation of the unit or is intended to make your work easier.

Safety notes

Safety notes are identified by pictograms - see "Safety Chapter".

Validity

These operating instructions conform to current EU regulations applicable at the time of publication.

Table of contents

1	Identity code.....	4
2	Overview of equipment	6
3	Safety chapter.....	7
4	Storage and Transport.....	10
5	Assembly and Installation.....	11
6	Maintenance.....	14
7	Repairs.....	15
8	Faults.....	18
9	Decommissioning.....	19
10	Technical data.....	20
11	Accessories.....	26
12	Dimensional drawings.....	27
13	EC / EU Declaration of Conformity for Machinery.....	31
14	Installation instructions for External + Level retrofit kit CNPb (Part no. 1022099).....	32

1 Identity code

Product range CONCEPT plus, Version b

CNP b	Type	
	--- _	Performance data at maximum back pressure and type: refer to nameplate on the pump housing
		Material
		PP Polypropylene
		NP Clear acrylic/PVC
		PV PVDF
		Diaphragm and seal
		E Standard with EPDM seals
		B Standard with FPM seals
		T Standard with PTFE flat seal
		Dosing head design
		0 Without bleed valve, without valve spring
		1 Without bleed valve, with valve spring
		2 With bleed valve, without valve spring
		3 With bleed valve, with valve spring
		Hydraulic connector
		0 Standard connection
		Design
		0 with ProMinent logo
		Electrical connections
		A 100 - 230 V, standard European plug
		B 100 - 230 V, Swiss plug
		C 100 - 230 V, Australian plug
		D 100 - 230 V, USA plug
		Cable assembly

Product range CONCEPT plus, Version b

									0	Without cable and retrofit kit
									A	With external and level input retrofit kit, loose, without level switch
									B	With external and level input retrofit kit, fitted, without level switch
									F	With level input, fitted, with level switch
									G	With external and level input, fitted, with external cable and level switch
									Accessories	
									0	without accessories
									1	Supplied accessories
									Control version	
									0	External contact

2 Overview of equipment

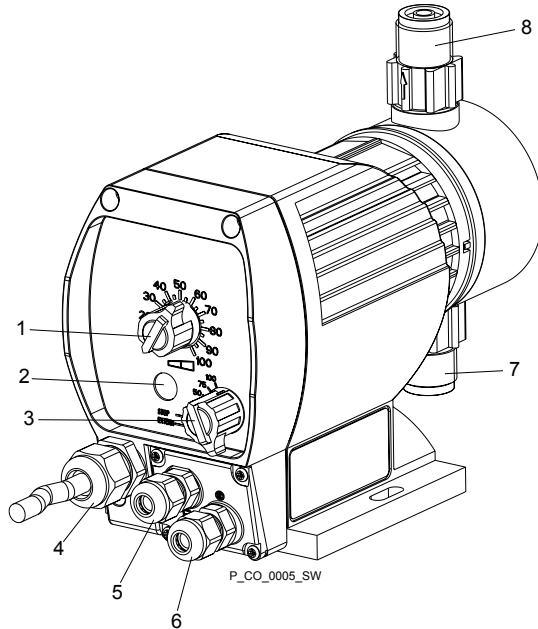

Fig. 2: Overview of equipment CONCEPT plus

- | | | | |
|---|--|---|--|
| 1 | Stroke length adjustment knob | 5 | "External control" terminal (in "External" operating mode, control via contact signal; optional) |
| 2 | Fault / operating indicator (fault red / operation green) | 6 | "Level switch" terminal (for 1-stage level switch; optional) |
| 3 | Multifunctional switch (stroke rates (in % of 180 or 240 strokes/min), Stop, "External" operating mode (retrofit kit)) | 7 | Suction valve |
| 4 | Mains cable | 8 | Discharge valve |

The leakage hole is between the suction valve and the drive housing.

3 Safety chapter



Explanation of the safety information

The following signal words are used in these operating instructions to identify different severities of a hazard:

Signal word	Meaning
WARNI NG	Denotes a possibly hazardous situation. If this is disregarded, you are in a life-threatening situation and this can result in serious injuries.
CAU- TION	Denotes a possibly hazardous situation. If this is disregarded, it could result in slight or minor injuries or material damage.

Warning signs denoting different types of danger

The following warning signs are used in these operating instructions to denote different types of danger:

Warning signs	Type of danger
	Warning – automatic start-up.
	Warning – high-voltage.
	Warning – danger zone.

Intended use

- Only use the pump to meter liquid feed chemicals.
- Only use the pump after it has been correctly installed and started up in accordance with the technical data and specifications contained in the operating instructions.
- Observe the general limitations with regard to viscosity limits, chemical resistance and density - see also ProMinent® resistance list in the Product Catalogue or at www.prominent.com!
- All other uses or modifications are prohibited.
- The pump is not intended for the metering of gaseous media and solids.
- The pump is not intended for the metering of flammable media without implementing suitable protective measures.
- The pump is not intended to meter explosive media.
- The pump is not intended for operation in areas at risk from explosion.
- The pump is not intended to meter radioactive media.
- The pump is not intended for exterior applications without the implementation of suitable protective measures.
- The pump is only intended for industrial use.
- The pump should only be operated by trained and authorised personnel. Ensure that personnel are familiar with oscillating metering pumps and their operation.
- Observe the information contained in the operating instructions at the different phases of the unit's service life.

Safety notes



WARNING!

Warning about personal and material damage

The pump can start to pump, as soon as it is connected to the mains voltage.

- Install an emergency cut-off switch in the pump power supply line or integrate the pump in the emergency cut-off management of the system.



WARNING!

Danger of electric shock

If there is a damaged housing or an opening is left open, the mains voltage inside is no longer sufficiently shielded.

- Disconnect the pump from the mains power supply if the housing is damaged or there is a gaping opening.



WARNING!

Danger from hazardous substances!

Possible consequence: Fatal or very serious injuries.

Please ensure when handling hazardous substances that you have read the latest safety data sheets provided by the manufacture of the hazardous substance. The actions required are described in the safety data sheet. Check the safety data sheet regularly and replace, if necessary, as the hazard potential of a substance can be re-evaluated at any time based on new findings.

The system operator is responsible for ensuring that these safety data sheets are available and that they are kept up to date, as well as for producing an associated hazard assessment for the workstations affected.



CAUTION!

Warning of feed chemical spraying around

Feed chemical can spray out of the hydraulic components if they are manipulated or opened due to pressure in the liquid end and adjacent parts of the system.

- Disconnect the pump from the mains power supply and ensure that it cannot be switched on again by unauthorised persons.
- Depressurise the system before commencing any work on hydraulic parts.

**CAUTION!****Warning of feed chemical spraying around**

The metering pump can generate a multiple of its rated pressure. Hydraulic parts may burst if a discharge line is blocked.

- Correctly install a back pressure valve in the discharge line behind the metering pump.

**CAUTION!****Warning of excessive demand**

The pump can meter too much if there is a negative pressure difference between the discharge and suction sides.

- For example with a free outlet, use a back pressure valve with a minimum opening pressure of 1.5 bar (not possible with 0213).

**CAUTION!****Danger of injury to personnel and material damage**

The use of untested third party components can result in injury to personnel and material damage.

- Only fit parts to metering pumps that have been tested and recommended by ProMinent.

**CAUTION!****Warning against illegal operation**

Observe the regulations that apply where the unit is installed.

Information in the event of an emergency

In an emergency, either pull out the mains plug, turn the multifunctional switch to "Stop" or press the Emergency Stop switch installed on the customer's side or disconnect the pump from the mains power supply in line with the emergency shut-down management guidelines for your system!

If feed chemical escapes, additionally ensure that the hydraulic system around the pump is at atmospheric pressure. Adhere to the safety data sheet for the feed chemical.

4 Storage and Transport



WARNING!

Only return the metering pump for repair in a cleaned state and with a flushed liquid end - refer to the section on decommissioning!

Only return metering pumps with a completed Decontamination Declaration form. The Decontamination Declaration constitutes an integral part of an inspection / repair order. We can only inspect or repair a unit if a Decontamination Declaration is submitted that has been completed correctly and in full by an authorised and qualified person on behalf of the pump operator.

The "Decontamination Declaration Form" can be found at www.prominent.com.

Ambient conditions

Data	Value	Unit
Minimum storage and transport temperature	-10	°C
Maximum storage and transport temperature	+50	°C
Maximum air humidity *	95	% rel. humidity

* non-condensing

5 Assembly and Installation



CAUTION!

Warning of feed chemical spraying around

The pipes can loosen or rupture if they are not installed correctly.

- Route all hose lines so they are free from mechanical stresses and kinks.
- Only use original hoses with the specified hose dimensions and wall thicknesses.
- Only use clamp rings and hose nozzles that are intended for the hose diameter in question to ensure the long service life of the connections.



CAUTION!

Warning of feed chemical spraying around

PTFE seals, which have already been used / compressed, can no longer reliably seal a hydraulic connection.

- Always use new, unused PTFE seals.



CAUTION!

Warning of excessive demand

The pump can meter too much if there is a negative pressure difference between the discharge and suction sides.

- For example with a free outlet, use a back pressure valve with a minimum opening pressure of 1.5 bar (not possible with 0213).



CAUTION!

Warning of destruction of the pump

An incorrect mains voltage or mains frequency can irreparably destroy the metering pump.

- Check that the mains voltage and frequency agree with the values given on the nameplate.



CAUTION!

Possibility of your switching relay contacts bonding

The high starting current can cause the contacts of the switching relay to bond together if the mains voltage switches a solenoid metering pump on and off in a process.

- Use the switching options offered by the external contact to control the pump (functions: Pause or Contact).
- Use a starting current limiter (part no. 1059333 for 230 V) if it is impossible to avoid switching the pump on and off via a relay.

CAUTION!

Material damage possible due to power surges

Should the pump be connected to the mains power supply in parallel to inductive consumers (such as solenoid valves, motors), inductive power surges can damage the control when it is switched off.

- Provide the pump with its own contacts (Phase) and supply with voltage via a contactor relay or relay.
- Should this not be possible, then switch a varistor (part no. 710912) or an RC gate (0.22 μ F/220 Ω , part no. 710802) in parallel.

CAUTION!

Warning against illegal operation

Observe the regulations that apply where the unit is installed.

Capacity too low

The liquid end valves can be disturbed by vibrations.

- Secure the metering pump so that no vibrations can occur.

Installation instructions for retrofit kit



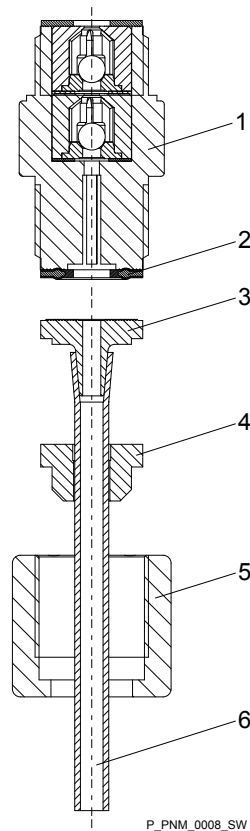

"Installation instructions for External + Level retrofit kit CNPb (Part no. 1046731)"
- see Appendix.

Installing the hose line



P_PNM_0008_SW

Fig. 3

1.  Assemble the metering pump on a storage tank or a bracket using screws and U-washers (\varnothing 6 mm).
2.  Cut the pressure hose to the required length.
3.  Pull the union nut (5) and clamping ring (4) over the hose line (6).
4.  Push the shortened hose end **up to the stop** over the nozzle (3).
5.  Press the hose (6) on and tighten the union nut (5).

6. ▶ Install the suction line.



To do this, shorten the free end of the suction line so that the foot valve hangs just above the base of the storage tank.

With feed chemicals with impurities or sediment, shorten the free end of the suction line so that the foot valve hangs at least 50 mm above the base of the storage tank.



Keep the suction line and the suction height as short as possible.

Route the suction line with an upwards slope.

7. ▶ Install a foot valve.

6 Maintenance

Interval	Maintenance work	Personnel
Quarterly*	<ul style="list-style-type: none"> ■ Check the metering diaphragm for damage** - refer to "Repair". ■ Check that the hydraulic lines are fixed firmly to the liquid end. ■ Check that the suction valve and discharge valve are correctly seated. ■ Check the leak-tightness of the entire liquid end - particularly around the leakage hole. ■ Check that the flow is correct: Allow the pump to prime briefly - turn the multifunction switch briefly to "100 %". ■ Check that the electrical connections are intact ■ Check the integrity of the housing. ■ Check that the dosing head screws are tight 	Technical personnel

* Under normal loading (approx. 30 % of continuous operation)

Under heavy loading (e.g. continuous operation): Shorter intervals.

** For feed chemicals which particularly load the diaphragm, e.g. those containing abrasive additives, check the diaphragm frequently.

Tightening torque

Data	Value	Unit
Tightening torque for screws:	4.5 ... 5.0	Nm

7 Repairs

Carry out repairs, which should be performed by qualified technical personnel, in line with the safety notes:

- Cleaning a valve
- Replacing the diaphragm

All other repairs: Contact your responsible ProMinent branch!

Replacing the diaphragm

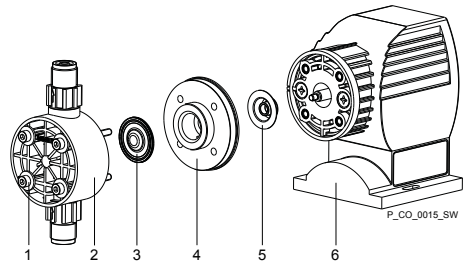

Fig. 4

- If necessary take protective measures.
 - Adhere to the safety data sheet for the feed chemical.
 - Ensure that the system is at atmospheric pressure.
1. ➤ Empty the liquid end (turn the liquid end upside down and allow the feed chemical to run out; flush out with a suitable medium; flush the liquid end thoroughly when using hazardous feed chemicals!)
 2. ➤ Turn the stroke adjustment dial as far as 0 % stroke length when the pump is running (the drive axle is then difficult to turn).
 3. ➤ Switch off the pump.
 4. ➤ Unscrew the hydraulic connectors on the discharge and suction side.
 5. ➤ Remove the screws (1).
 6. ➤ Loosen the dosing head (2) and the backplate (4) from the pump housing (6) - but only loosen!
 7. ➤ Hold the pump housing (6) with one hand and clamp the diaphragm (3) with the other hand between the dosing head (2) and the backplate (4).
 8. ➤ Loosen the diaphragm (3) from the drive axle with a gentle backwards turn of the dosing head (2), diaphragm (3) and backplate (4) in an anticlockwise direction.

Repairs

9. ➤ Unscrew the diaphragm (3) completely from the drive axle.
10. ➤ Remove the backplate (4) from the pump housing (6).
11. ➤ Check the condition of the safety diaphragm (5) and replace if necessary.
12. ➤ Push the safety diaphragm (5) onto the drive axle only until it lies flush with the pump housing (6) and no further!
13. ➤ Tentatively screw the new diaphragm (3) onto the drive axle until it can go no further.
 - ⇒ The diaphragm (3) is now sitting at the stop of the thread.
14. ➤ Should this not work, remove dirt or swarf from the threads and screw the diaphragm (3) onto the drive axle correctly this time.



Ensure that the diaphragm is screwed exactly onto the drive axle otherwise the pump will subsequently not meter accurately!

15. ➤ Unscrew the diaphragm (3) again.
16. ➤ Place the backplate (4) onto the pump housing (6).



CAUTION!

Leakage may become apparent at a later stage.

- Make sure that the leakage hole points downwards when the pump is installed later - please refer to !
- Place the backplate (4) immediately in the correct position on the pump housing (6)! Do not twist the backplate on the pump housing to prevent the safety diaphragm (5) becoming warped!

17. ➤ Place the diaphragm (3) into the backplate (4).



CAUTION!

Leakage may become apparent at a later stage.

- Do not over-tighten the diaphragm (3) in the following step!
- Ensure that the backplate (4) remains in its position so that the safety diaphragm does not become warped!

18. ➤ Hold the backplate (4) firmly and screw the diaphragm (3) in a clockwise direction until it is sitting tightly (the twisting resistance of the return spring can be felt).
19. ➤ Set the stroke length to 100 %.
20. ➤ Place the dosing head (2) with the screws (1) onto the diaphragm (3) and the backplate (4) - ensure that the suction connector points downwards when the pump is subsequently fitted.

21. Gently tighten the screws (1) and then tighten them diagonally. See below for tightening torque.

- With PP and PV dosing heads, check the tightening torque again after three months!

**CAUTION!****Leakage possible**

- Check the tightening torque of the screws after 24 hours of operation!

Tightening torque

Data	Value	Unit
Tightening torque for screws:	4.5 ... 5.0	Nm

8 Faults

Fault description	Cause	Remedy
Pump does not prime in spite of full stroke motion and bleeding.	Minor crystalline deposits on the ball seat due to the valves drying out	Take the suction hose out of the storage tank and thoroughly flush out the liquid end
	Major crystalline deposits on the ball seat due to the valves drying out	Dismantle and clean the valves.
Fluid is escaping from the backplate.	The screws in the dosing head are too loose	Tighten the screws in the dosing head crosswise - see below for the tightening torque.
	The diaphragm is not tight.	Replace the diaphragm - refer to "Repair".
Fault/operating indicator does not illuminate.	The wrong mains voltage or no mains voltage is connected.	Connect the pump correctly to the specified mains voltage - according to the specification on the nameplate
Fault/operating indicator is red.	The fluid level in the storage tank has reached "Liquid level low".	Fill the storage tank.
	The multifunctional switch is positioned between 2 selection options.	Allow the multifunctional switch to lock into selection option 1.
	Electronics fault	Return the pump.

Tightening torque

Data	Value	Unit
Tightening torque for screws:	4.5 ... 5.0	Nm

9 Decommissioning



WARNING!

Danger from chemical residues

There is normally chemical residue in the liquid end and on the housing after operation. This chemical residue could be hazardous to people.

- It is mandatory that the safety information relating to the "Storage, transport and unpacking" chapter is read before shipping or transporting the unit.
- Thoroughly clean the liquid end and the housing of chemicals and dirt. Observe the safety data sheet for the feed chemical.



CAUTION!

Environmental hazard due to electronic waste

There are electronic components in the pump, which can have a toxic effect on the environment.

- Separate the electronic components from the remaining parts.
- Note the pertinent regulations currently applicable in your country!

10 Technical data

CNPb performance table for 180 strokes/min

Type	Minimum pump capacity at maximum back pressure			Minimum pump capacity at medium back pressure			Connector size outside Ø x inside Ø	Suction lift*	Priming lift**	Max. priming pressure on the suction side
	bar	l/h	ml/stroke	bar	l/h	ml/stroke				
concept ^{plus}										
1000	10	0.74	0.07	5.0	0.97	0.09	6x4	6.0	1.8	8
1601	16	1.1	0.10	8.0	1.4	0.13	6x4	6.0	2.0	8
1002	10	2.1	0.19	5.0	2.6	0.24	6x4	5.0	2.5	5
0704	7	3.9	0.36	3.5	4.4	0.41	6x4	4.0	3.0	3
0309	3	9.0	0.83	1.5	13.0	1.20	8x5	2.0	2.0	1
0215	1.5	16.4	1.52	1.0	18.3	1.70	8x5	1.5	1.5	0.5
concept ^{plus} metering pumps with self-bleeding dosing head SER***										
1002	10	1.8	0.17	5.0	2.7	0.2	6x4	1.8	1.8	5
0704	7	3.0	0.28	3.5	4.3	0.4	6x4	1.8	1.8	3
0309	3	9.0	0.83	1.5	13.6	1.3	8x5	1.8	1.8	1
0215	1.5	13.2	1.22	-	-	-	8x5	1.8	1.8	0.5

CNPb performance table for 240 strokes/min

Type	Minimum pump capacity at maximum back pressure			Minimum pump capacity at medium back pressure			Con- nector size outside Ø x inside Ø	Suc- tion lift*	Pri- ming lift**	Max. priming pres- sure on the suction side
	bar	l/h	ml/ strok e	bar	l/h	ml/ stroke				
concept ^{plus}										
1001	10	1.0	0.07	5.0	1.3	0.09	6x4	6.0	1.8	8
1602	16	1.5	0.10	8.0	1.9	0.13	6x4	6.0	2.0	8
1003	10	3.0	0.21	5.0	4.3	0.30	6x4	5.0	2.5	5
0705	7	5.2	0.36	3.5	5.9	0.41	6x4	4.0	3.0	3
0312	3	12.0	0.83	1.5	17.3	1.20	8x5	2.0	2.0	1
0223	1.5	21.9	1.52	1.0	25.2	1.75	8x5	1.5	1.5	0.5
concept ^{plus} metering pumps with self-bleeding dosing head SER***										
1003	10	2.4	0.17	5.0	3.06	0.25	6x4	1.8	1.8	5
0705	7	4.2	0.29	3.5	5.2	0.36	6x4	1.8	1.8	3
0312	3	12.9	0.83	1.5	17.6	1.22	8x5	1.8	1.8	1
0223	1.5	18.6	1.29	-	-	-	8x5	1.8	1.8	0.5

* Suction lifts with a filled suction line and filled liquid end

** Priming lifts with clean and moist valves, feed chemical water (20 °C), at 100% stroke length, max. stroke rate, free outlet or opened bleed valve and correctly installed piping.

***The given performance data constitutes guaranteed minimum values, calculated using medium water at room temperature. The bypass connection with a self-bleeding dosing head is 6x4 mm.

Technical data

Material Specifications

Material type	Dosing head	Suction/pressure connector	Seals	Valve balls
PPT	Polypropylene	Polypropylene	PTFE	Ceramic
PPE	Polypropylene	Polypropylene	EPDM	Ceramic
PPB	Polypropylene	Polypropylene	FPM-B	Ceramic
NPT	Clear acrylic	PVC	PTFE	Ceramic
NPE	Clear acrylic	PVC	EPDM	Ceramic
NPB	Clear acrylic	PVC	FPM-B	Ceramic
PVT	PVDF	PVDF	PTFE	Ceramic

Diaphragm: with a PTFE coating

Housing: PPE, fibreglass-reinforced

Electrical data

CNPb 100 ... 230 VAC \pm 10%, 50 Hz/60 Hz

Specification	180 strokes/min	240 strokes/min
Nominal power	11.1 ... 10.5 W	14.3 ... 13.4 W
Current I eff	0.4 ... 0.2 A	0.46 ... 0.22 A
Peak current	1.5 A	1.5 A
Fuse*	1.6 AT	1.6 AT

* Fuses must have VDE, UL and CSA certification!

Technical data for the inputs (contact input, level input)

Data	Value	Unit
Voltage with open contacts	5 ± 0.5	VDC
Input resistance	12 ± 0.5	kΩ
Short circuit current	0.5 ± 0.05	mA
Maximum level for "0" signal	1.0	V
Maximum level for "1" signal	3.5	V
Minimum closing time of contact input	20	ms
Reaction time of level input	2	s

Temperatures

CAUTION!
The 240 stroke version may fail

The 240 stroke version can overheat at ambient temperatures higher than 35 °C.

- Only use the 240 stroke version at ambient temperatures of less than 35 °C.

Data	Value	Unit
Storage and transport temperature	-10 ... +50	°C
Ambient temperature during operation	-10 ... +45	°C

Maximum permissible medium temperature

Dosing head material	Long term at max. back pressure	For max. 15 min at max. 2 bar
PPE / PPB / PPT	50 °C	100 °C
NPE / NPB	45 °C	45 °C
NPT	45 °C	60 °C
PVT	60 °C	120 °C

Technical data

Climate

Data	Value	Unit
Maximum air humidity*:	95	% relative humidity

*non-condensing

Enclosure rating and protection class

Protection against contact and humidity:

IP 65 in accordance with IEC 529, EN 60529,
DIN VDE 0470 Part 1

Degree of protection:

1 - mains power connection with protective
earth conductor

Shipping weight

Specification	Value	Unit
Shipping weight	1.8	kg

Sound pressure level

Sound pressure level LpA < 75 dB in accordance with EN ISO 20361 (Type 1000)

Sound pressure level LpA < 70 dB in accordance with EN ISO 20361 (all other types)

at maximum stroke length, maximum stroke rate, maximum back pressure (water)

11 Accessories

Suction lances

Article	Order no.
Suction lance for 200 l drum, storage tank opening 2" DIN 570, PPE	1022511
Suction lance for 200 l drum, storage tank opening 2" DIN 570, PCB	1022512
Suction lance for storage tank 5 - 50 l drum, storage tank opening d50, PPE	1022645
Suction lance for storage tank 5 - 50 l drum, storage tank opening d50, PCB	1022644

Variable suction lance with 1-stage level switch, closes when the chemical level is low.

Retrofit kits

Article	Order no.
External + level input retrofit kit CNPb	1022099
Level input retrofit kit CNPb	1022115

12 Dimensional drawings



Dimensions in mm

CONCEPT plus with bleed valve, PP and NP

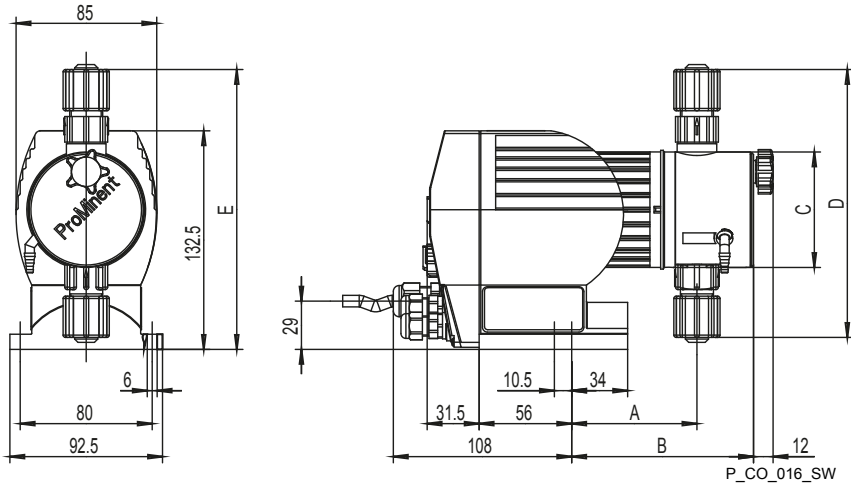

Types	A	B	C	D	E
0309-0213	79	112	90	178	176
1000-0704	76	110	70	162	170

CONCEPT plus without bleed valve, PP and NP

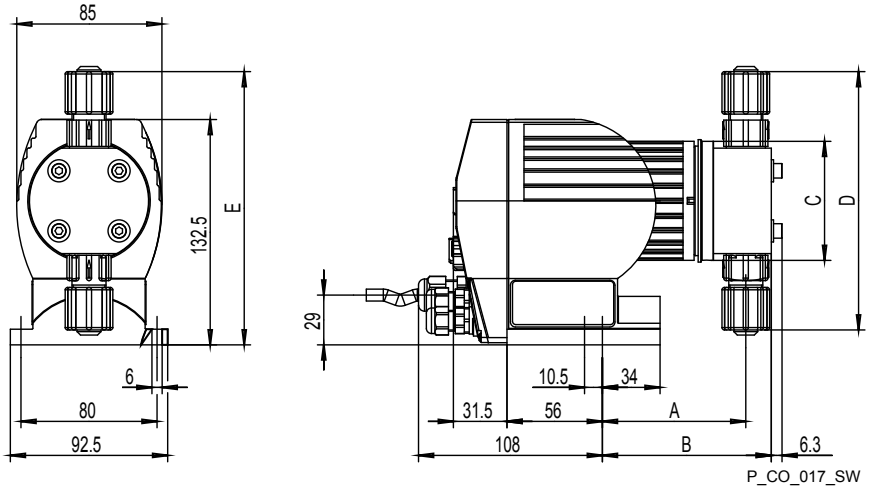

Types	A	B	C	D	E
0309-0213	81	96	90	175	172
1000-0704	84	99	70	152	161

Dimensional drawings

CONCEPT plus PV

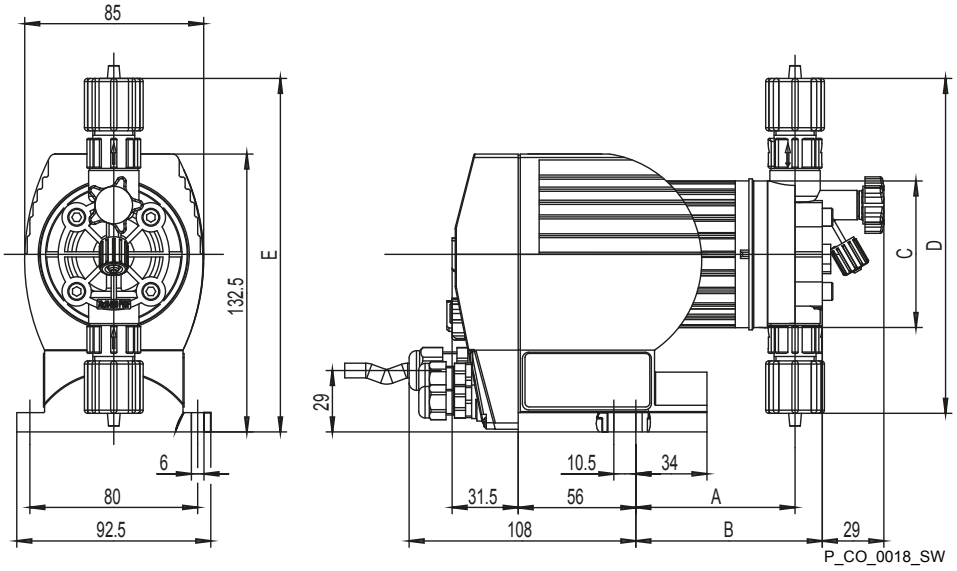

Types	A	B	C	D	E
0309-0213	78	95	90	177	175
1000-0704	76	89	70	160	169

13 EC / EU Declaration of Conformity for Machinery

In accordance with DIRECTIVE 2006/42/EC OF THE EUROPEAN PARLIAMENT AND OF THE COUNCIL, Appendix I, BASIC HEALTH AND SAFETY REQUIREMENTS, section 1.7.4.2. C.

We,

- ProMinent GmbH
- Im Schuhmachergewann 5 - 11
- D - 69123 Heidelberg,

hereby declare that the product specified in the following, complies with the relevant basic health and safety requirements of the EC Directive, on the basis of its functional concept and design and in the version distributed by us.

Any modification to the product not approved by us will invalidate this declaration.

Extract from the EC / EU Declaration of Conformity

Designation of the product:	Metering pump, CONCEPT ^{plus} product range	
Product type:	CNPb...	
Serial number:	see nameplate on the device	
Relevant EC directives:	Machinery Directive (2006/42/EC)	
	Compliance with the protection targets of the Low Voltage Directive according to Appendix I, No. 1.5.1 of the Machinery Directive 2006/42/EC	
	EU RoHS Directive (2011/65/EU)	
	up to 19.04.2016	from 20.04.2016
	EMC Directive (2004/108/EC)	EMC Directive (2014/30/EU)
Harmonised standards applied, in particular:	EN ISO 12100: 2010	
	EN 809:1998 + A1:2009 + AC:2010	
	EN 61010-1:2010	
	EN 50581:2012	
	EN 61000-6-2:2005 + AC:2005	
	EN 61000-6-3:2007 + A1:2011 + AC:2012	
Date:	26/01/2016	

You will find the EC Declaration of Conformity to download on our homepage.

14 Installation instructions for External + Level retrofit kit CNPb (Part no. 1022099)

Connector for external control (External operating mode)

Scope of delivery

1 cable, 2 m; 1 cable threaded connector; 1 nut; 2 plugs; 1 Torx key, TX9

A contact or an electronic switch (contact control, e.g. contact water meter) can be connected to the 3-wire cable for the external control of the pump. The pump reacts to the contact closing. The pump reacts to the contact opening with the Pause function.

Installation

WARNING!

- Ensure that only trained and authorised personnel install the retrofit kit.
- Disconnect the pump from the mains power supply and secure to prevent switching on again.

External control connectors

Colour	Function
GND	black
Contact	blue
Pause	brown

- Unscrew the cover at the bottom right on the front of the pump.
- Punch open the marked openings.
- Push the nut into each recess on the inside of the cover and tighten the lower part of the cable screw connectors to make them watertight.
- Thread the external cable and the suction lance cable through a threaded cable connector.
- Connect the plugs to the ends of the cables.
To do so, push a screwdriver (0.4x2.5x75 mm) into the one hole and guide the cable end into the other hole.
- Insert the plugs into the respective recesses on the PCB in the pump.
- Screw the cover back onto the pump and tighten the threaded cable connectors until they are watertight.

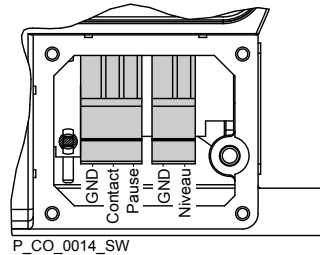

Fig. 5: View of the inserted plugs in the open pump - external control on the left, level alarm on the right.







ProMinent GmbH
Im Schuhmachergewann 5-11
69123 Heidelberg
Germany
Telephone: +49 6221 842-0
Fax: +49 6221 842-419
Email: info@prominent.com
Internet: www.prominent.com

Heidelberg, 2, en_GB

© 2010

ProMinentGroup.ir

1 Diagrams for adjusting the capacity

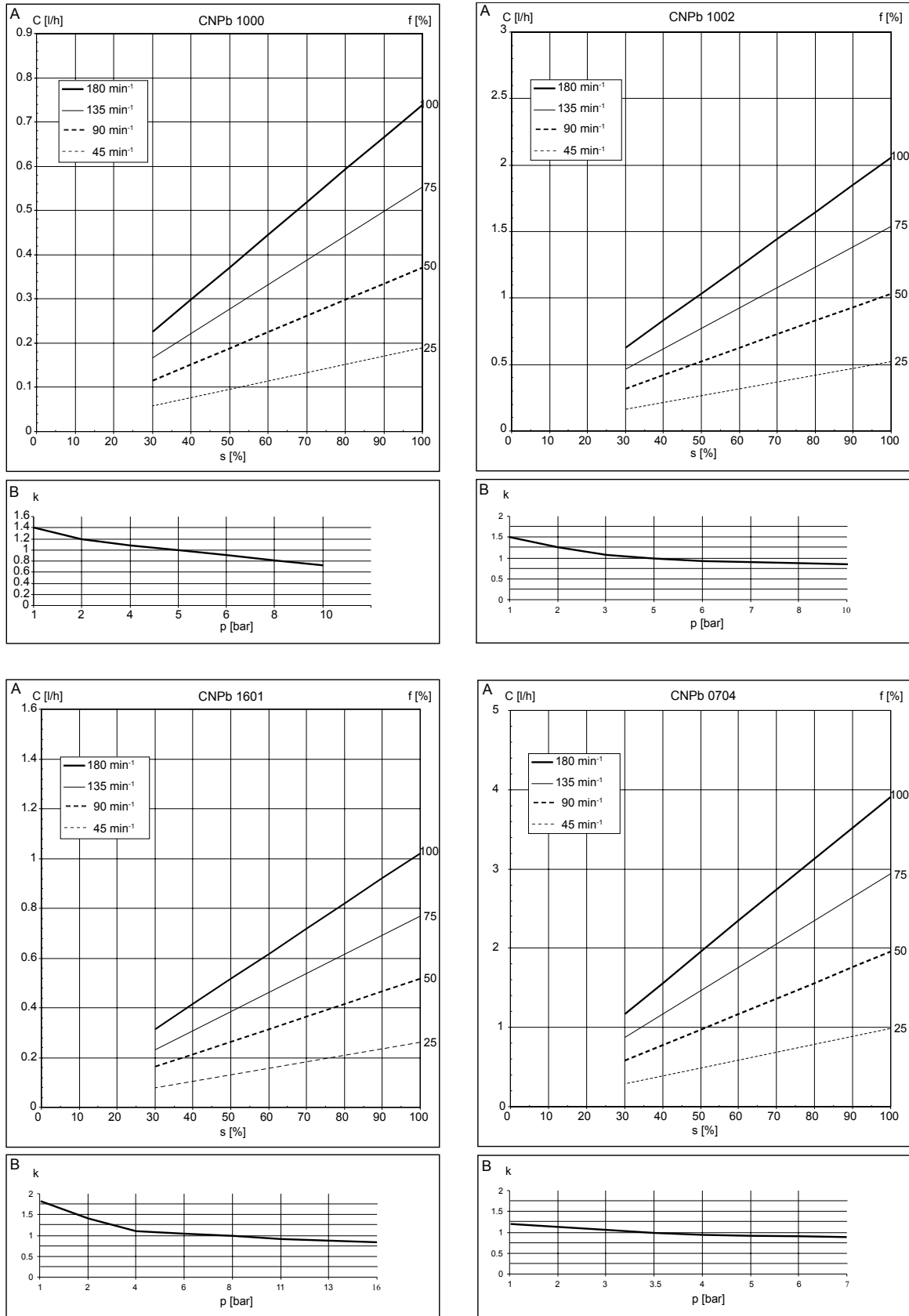

Fig. 1: A) Capacity C for medium back pressure dependent on the stroke length s for different stroke rates f. B) Corresponding correction factors k dependent on back pressure p.

Diagrams for adjusting the capacity

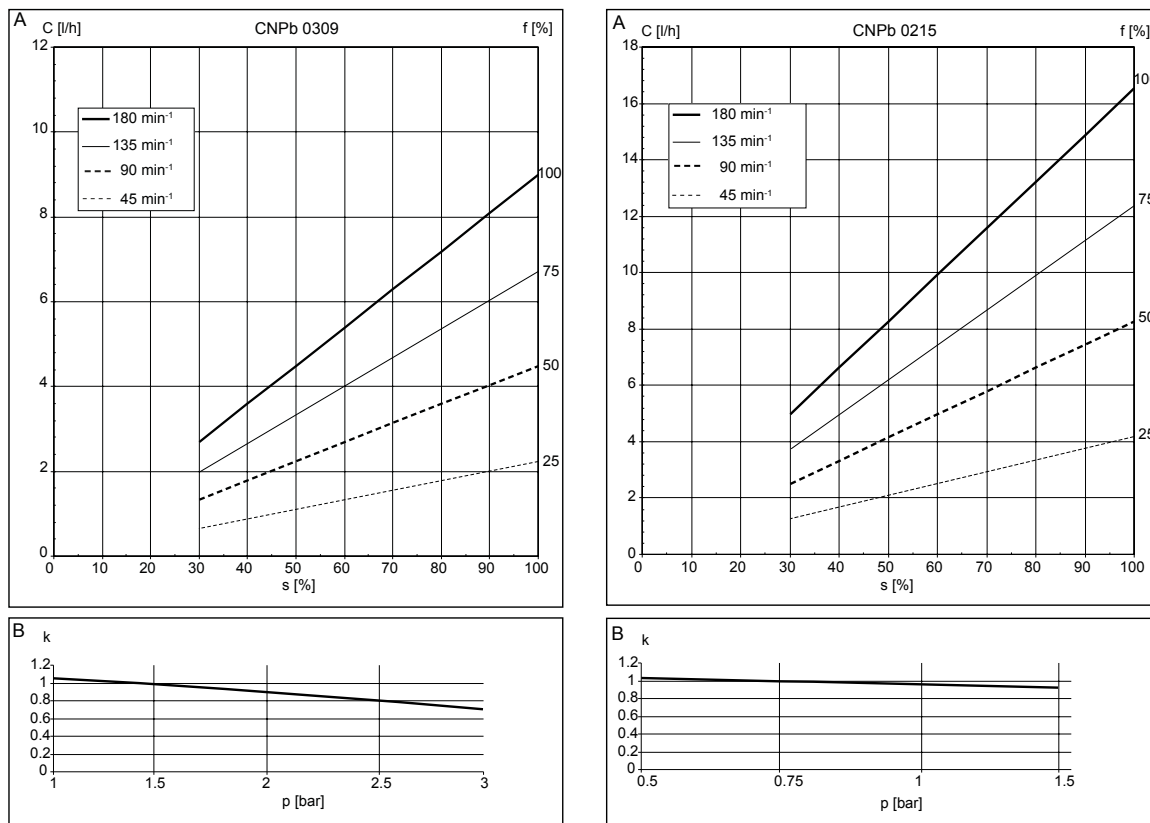

Fig. 2: A) Capacity C for medium back pressure dependent on the stroke length s for different stroke rates f .
 B) Corresponding correction factors k dependent on back pressure p .

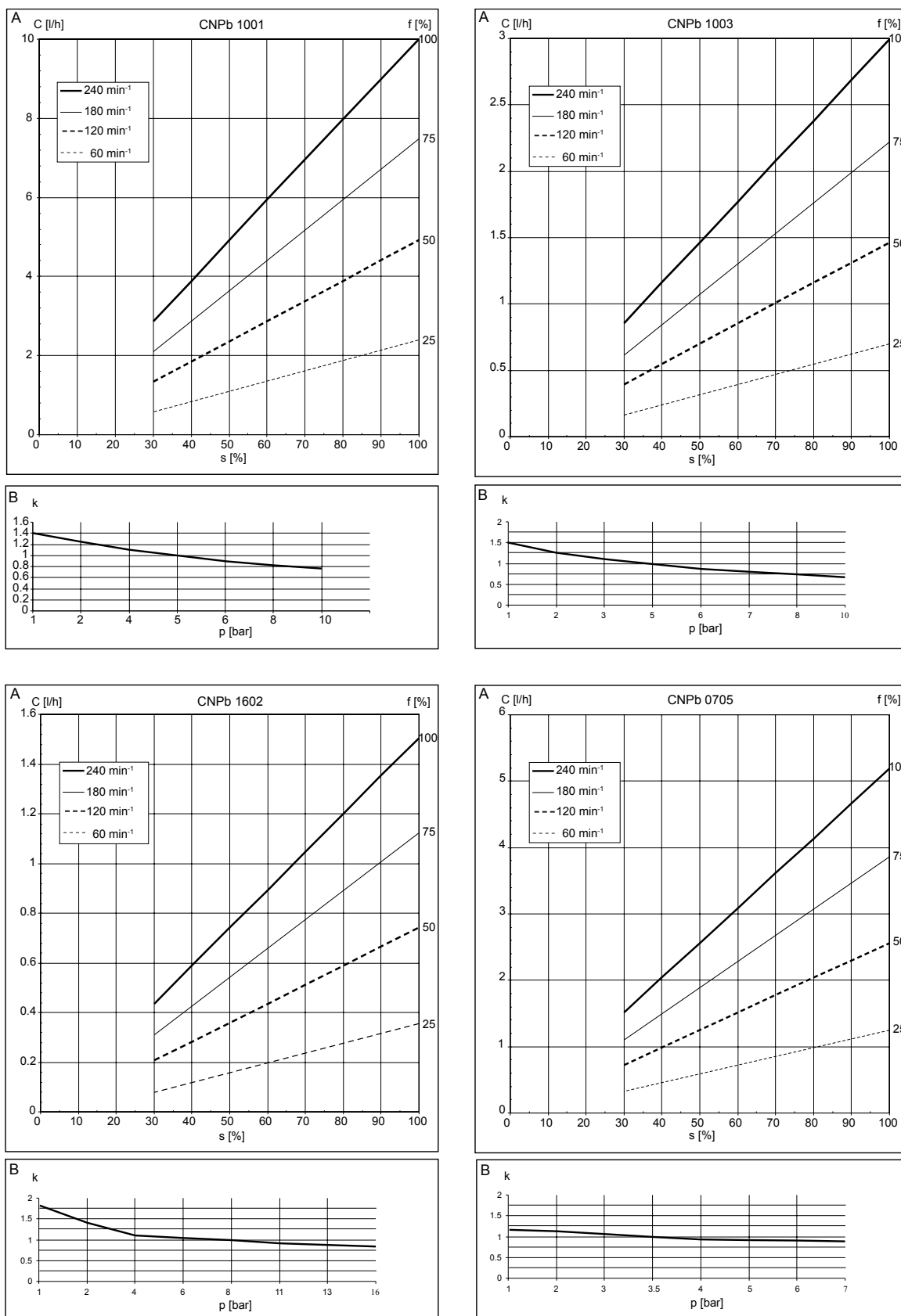

Fig. 3: A) Capacity C for medium back pressure dependent on the stroke length s for different stroke rates f . B) Corresponding correction factors k dependent on back pressure p .

Diagrams for adjusting the capacity

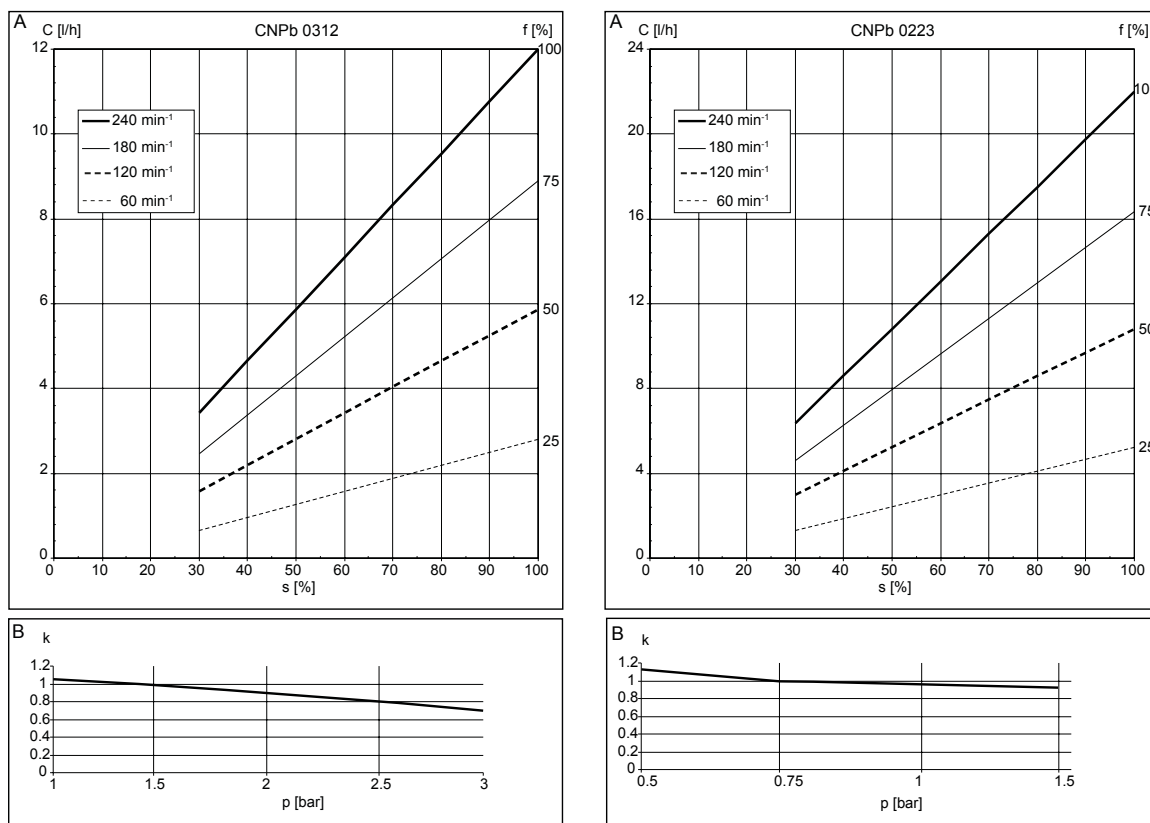

Fig. 4: A) Capacity C for medium back pressure dependent on the stroke length s for different stroke rates f. B) Corresponding correction factors k dependent on back pressure p.